



PPA-Relevant Clustering-Driven Placement for Large-Scale VLSI Designs

Andrew B. Kahng¹, Seokhyeong Kang², Sayak Kundu¹,
Kyungjun Min², Seonghyeon Park² and Bodhisatta Pramanik¹

[1] University of California San Diego [2] Pohang University of Science and Technology



[Paper]

Motivation

Challenges for modern designs



A solution to the challenge: **clustering!**

Objective: **improve both runtime and PPA**

Key features

- 1 PPA-aware clustering → generates high-quality clusters
- 2 Virtualized place and route → estimates cluster shapes

Overall Flow

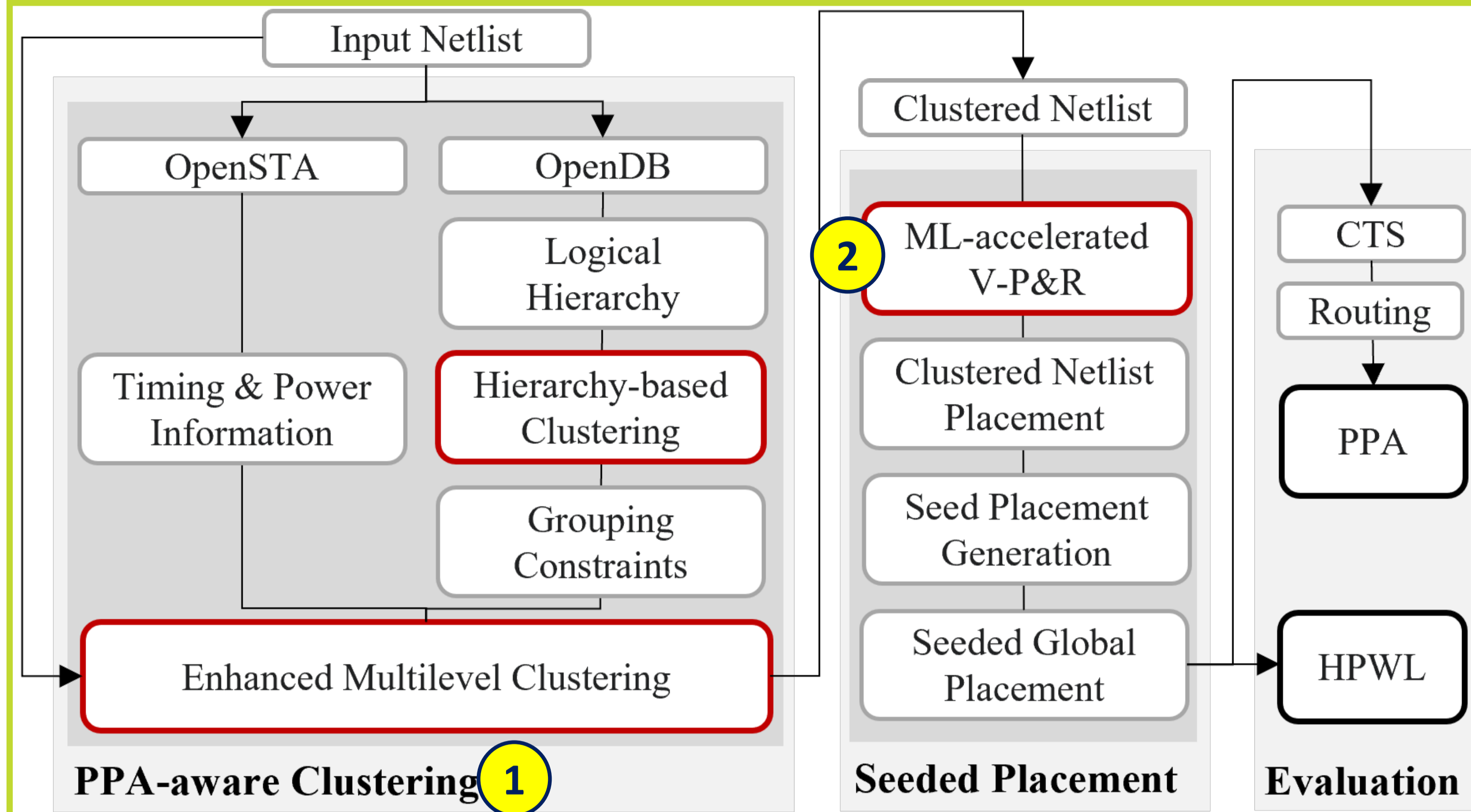

Methodology

PPA-aware Clustering

Hierarchy-based clustering

- Hierarchy tree → dendrogram → clusters with lowest Rent's parameter → grouping constraints

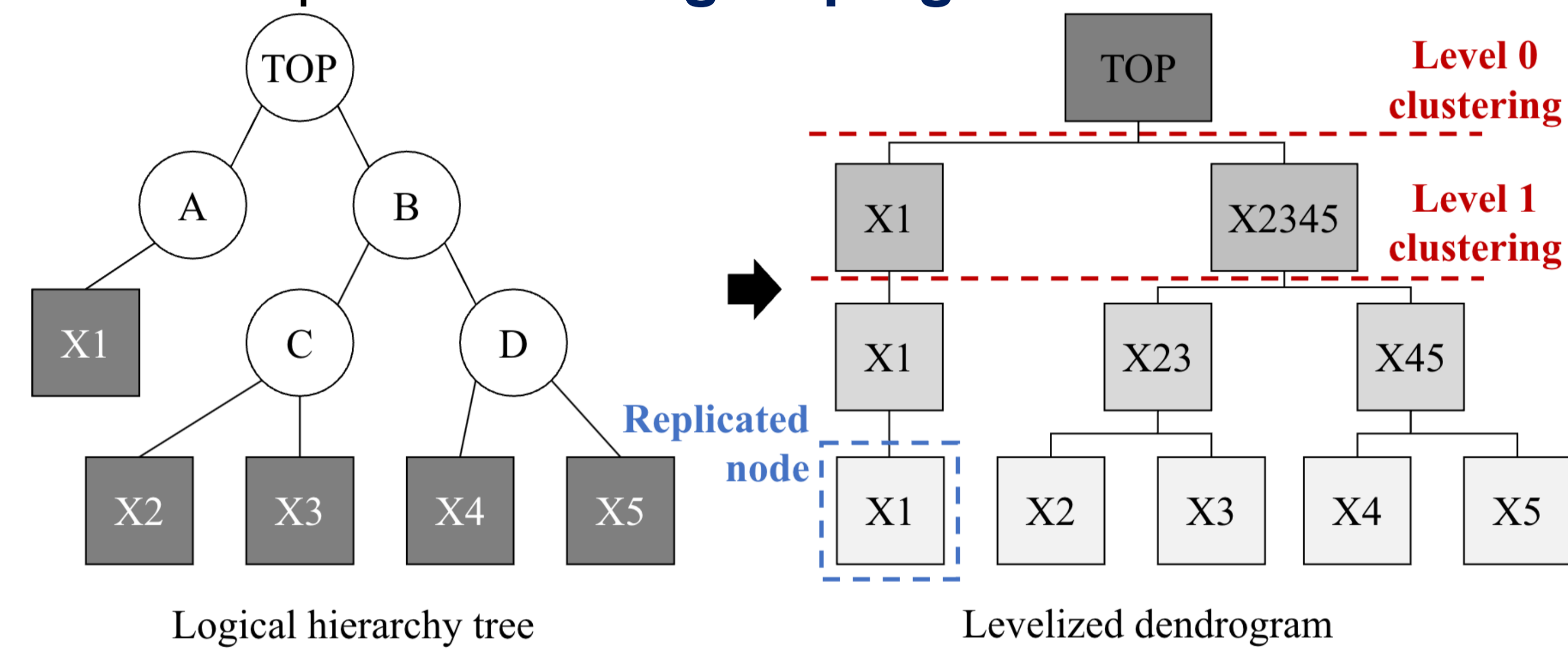

Enhanced multi-level clustering ← with grouping constraints

- Connectivity score + timing score + power score

Timing score

- Timing-based clustering score for a pair of vertices u and v :

$$\sum_{e \in \{I(v) \cap I(u)\}} \frac{\beta t_e}{|e| - 1}$$

- Timing cost of a hyperedge:

$$t_e = f(\text{net criticality}) + f(\text{critical paths in } e)$$

Power score

- Power-based clustering score for a pair of vertices u and v :

$$\sum_{e \in \{I(v) \cap I(u)\}} \frac{\beta s_e}{|e| - 1}$$

- Switching cost of a hyperedge:

$$s_e = f(\text{switching activity})$$

Virtualized P&R

Virtualized P&R (V-P&R)

- Select cluster shapes i.e., utilizations and aspect ratios (from a set of candidates) with lowest cost
- P&R on sub-netlists induced by clusters ← to get cost

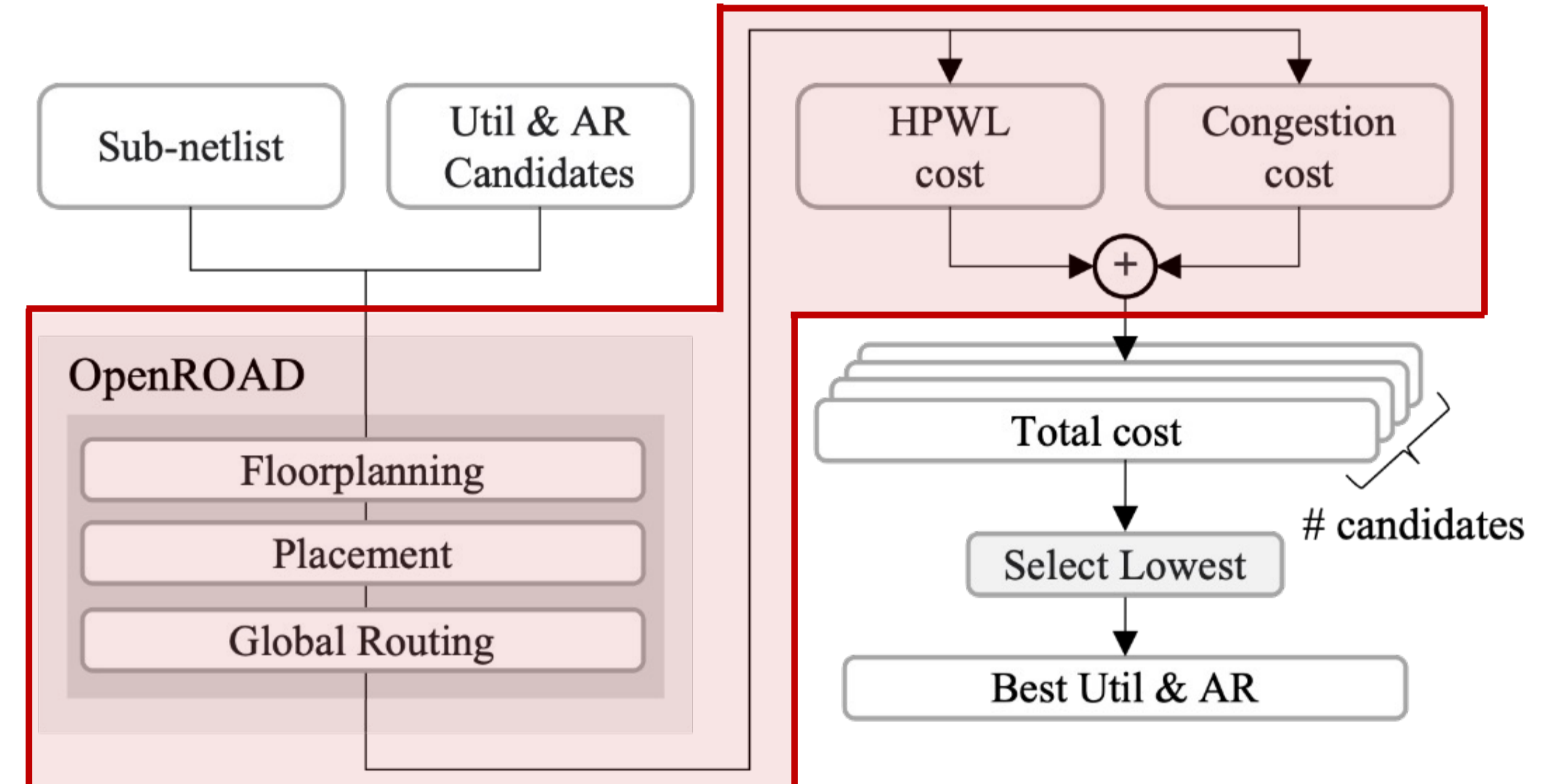

ML-accelerated V-P&R (30x faster)

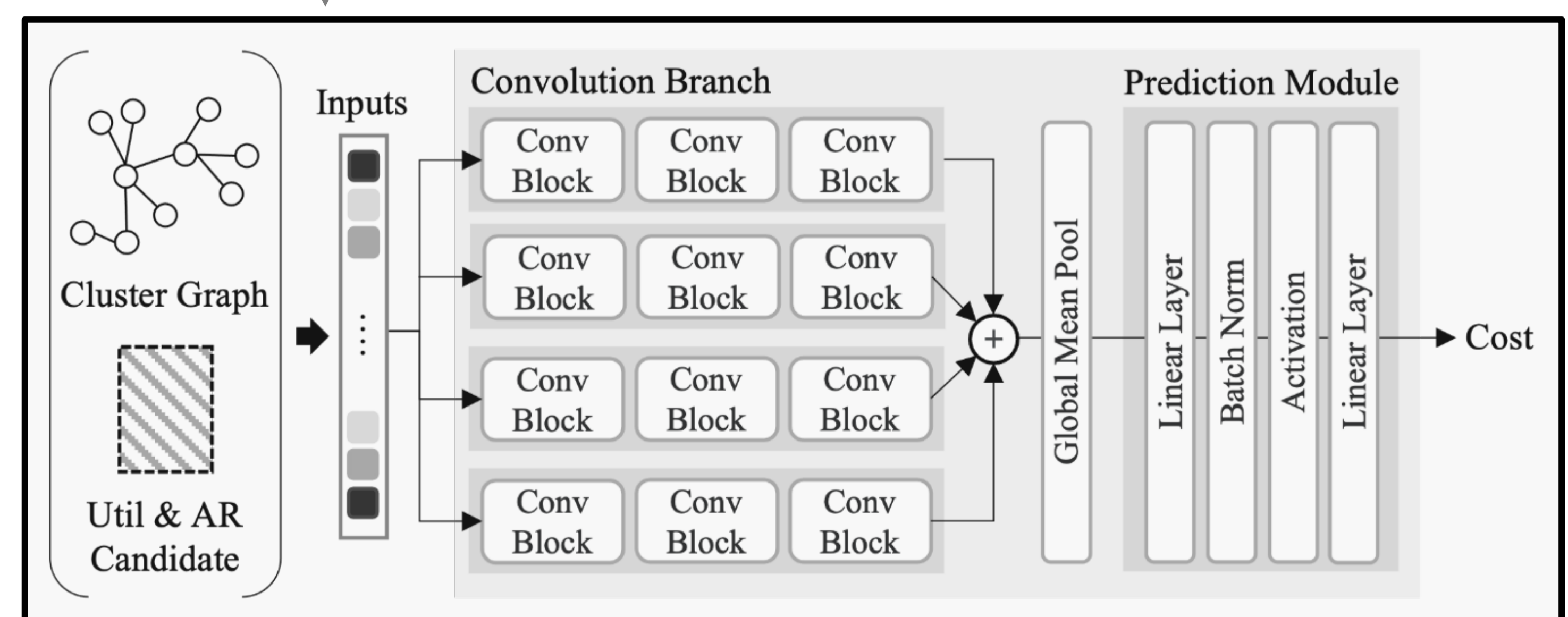

Experimental Result

OpenROAD-based flow

Design	Flow	Post-route PPA			
		rWL	WNS	TNS	Power
aes	Default	1.00	-1.00	-1.00	1.00
	Ours	0.98	-0.95	-0.99	0.99
jpeg	Default	1.00	-1.00	-1.00	1.00
	Ours	0.95	-1.15	-1.36	0.99
ariane	Default	1.00	-1.00	-1.00	1.00
	Ours	0.99	-0.50	-0.10	1.01
BP	Default	1.00	-1.00	-1.00	1.00
	Ours	0.99	-0.37	-0.39	1.00

29% average TNS improvement

Innovus-based flow

Design	Flow	Post-route PPA			
		rWL	WNS	TNS	Power
aes	Default	1.00	-1.00	-1.00	1.00
	Ours	0.99	-0.83	-0.88	1.04
jpeg	Default	1.00	-1.00	-1.00	1.00
	Ours	1.03	-0.15	-0.060	0.99
ariane	Default	1.00	-1.00	-1.00	1.00
	Ours	0.98	-0.87	-0.55	0.99
BP	Default	1.00	-1.00	-1.00	1.00
	Ours	1.07	-0.99	-0.99	1.00
MB	Default	1.00	-1.00	-1.00	1.00
	Ours	0.97	-0.43	-0.22	0.98
MP-G	Default	1.00	-1.00	-1.00	1.00
	Ours	0.99	-0.78	-0.66	1.00

49% average TNS improvement

Conclusion

- PPA-aware Clustering:** Multilevel clustering framework that considers logical hierarchy, timing paths and switching activities
- ML-Accelerated V-P&R Framework:** Predicts aspect ratios and utilizations for clusters that improves PPA
- Experimental Results:**
 - Integration with OpenROAD tool shows **29% average TNS improvement** and **36% runtime speedup**
 - Integration with Cadence Innovus tool shows **49% average TNS improvement**